

ACTION ITEMS

TEAM: Team 4 Open Source 3D Printed Foot Prosthesis

Due Date:

Monday, April 22, 2019 5:30pm

The following are the Action Items from last week:

Team Member: Ali Abdullah

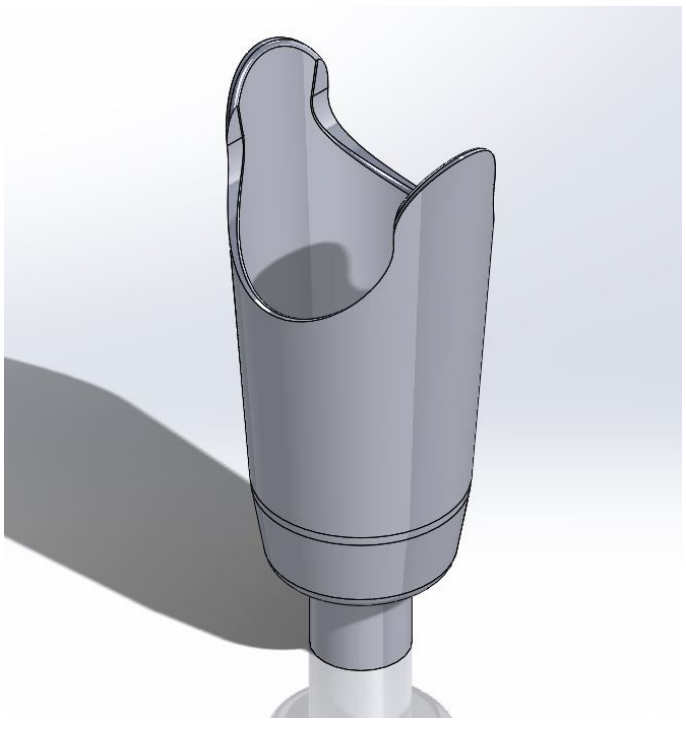
Action Item	Date Due	Date Completed	Result/Proof of Completion
Made final edits on the supporting channel in CAD, because the last one Salman and Abdulwahab took it to Jenn and they have confirmed that it fit perfectly, but in the upper part was annoying her because it is tight. So I and Salman have increased the radius of the upper part near the thigh from 2.5 to 2.8 inches, which gives her more circumference about 1.88 inch. We also have deleted the extra corners in the upper part so it would be more comfortable for her to wear.	04/16/2019	04/16/2019	

<p>Me and Salman have increased the incline of the foot so that it will give the foot more strength in the middle when applied weight at an angle, even though the foot withstands 300 lbs based on the test that Abdulwahab and Salman did last week.</p>	<p>04/16/2019</p>	<p>04/16/2019</p>											
<p>Me and Salman ordered the final foot and the final supporting channel to be 3D printed from Cline Library to use them also in the final presentation. They have been printed and ready to use.</p>	<p>04/16/2019</p>	<p>04/21/2019</p>	<div style="text-align: center;">  </div> <hr/> <div style="display: flex; justify-content: space-between;"> <div> <p>Receipt</p> </div> <div> <p>Date: 04-21-2019 Order Number: 19040001973640080F2500406027</p> </div> </div> <hr/> <p>PLEASE DO NOT REPLY TO THIS EMAIL! This email has been automatically generated.</p> <hr/> <p>Billing Information</p> <p>salman malallah 3601. lake mary Flagstaff AZ US 86001</p> <p>ssm264@nau.edu 4807998680</p> <hr/> <table border="0" style="width: 100%;"> <tr> <td colspan="3">Order Items</td> </tr> <tr> <td>128915 Cline Library 3D Pri...</td> <td style="text-align: center;">x 1</td> <td style="text-align: right;">\$38.98</td> </tr> </table> <hr/> <table border="0" style="width: 100%;"> <tr> <td style="width: 60%;">Payment Details</td> <td style="width: 40%;">Order Total</td> </tr> <tr> <td> Visa xxxxxxxxxxxx5369 </td> <td style="text-align: right;">Total amount \$38.98</td> </tr> </table> <hr/> <p>Please keep a copy of this email for your records. PLEASE DO NOT REPLY TO THIS EMAIL! This email has been automatically generated. If you have questions regarding this transaction, please contact the department that originated the transaction.</p>	Order Items			128915 Cline Library 3D Pri...	x 1	\$38.98	Payment Details	Order Total	Visa xxxxxxxxxxxx5369	Total amount \$38.98
Order Items													
128915 Cline Library 3D Pri...	x 1	\$38.98											
Payment Details	Order Total												
Visa xxxxxxxxxxxx5369	Total amount \$38.98												



Receipt

Date: 04-19-2019
Order Number: 19040001973640080F2500405874

PLEASE DO NOT REPLY TO THIS EMAIL! This email has been automatically generated.

Billing Information

Salman Malallah
3601 Lake Mary Rd.
Flagstaff
AZ
US
86001

ssm264@nau.edu
4807998680

Order Items

128916 Cline Library 3D Pri... x 1 \$35.78

Payment

Details
Visa
xxxxxxxxxxxx5369

Order Total

Total amount \$35.78

Please keep a copy of this email for your records.
PLEASE DO NOT REPLY TO THIS EMAIL! This email has been automatically generated.
If you have questions regarding this transaction, please contact the department that originated the transaction.

Team Member: Salman Malallah

Action Item	Date Due	Date Completed	Result/Proof of Completion
(With Omar) Worked on the final draft of poster and editing it based on Amy's feedback such as used a correct logo for NAU, alphabetize last names, and changed the abstract to be longer.	04-19-2019	04-19-2019	Submitted on BB-learn.

(With Ali) Made the final edits on the supporting channel and the foot to be fitting on Jenn's leg.

1. We increased the radius of the supporting channel of the upper part near the thigh from 2.5 to 2.8 inches.
2. The foot design has been changed to withstand heavyweights.

-We ordered them from Cline Library to be printed.

04/16/2019

04/21/2019

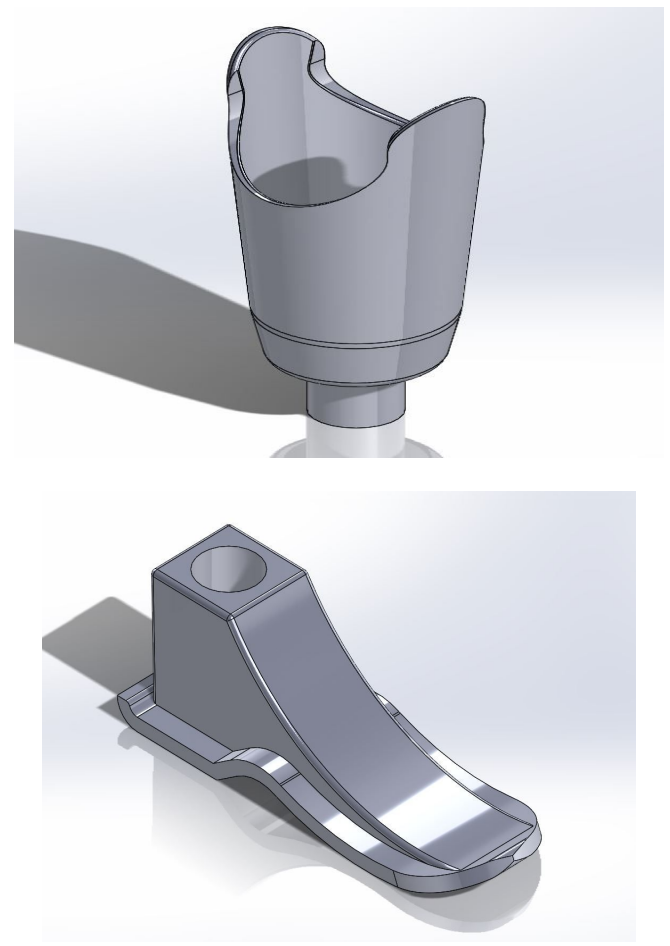

Receipt

Date: 04-21-2019
Order Number: 19040001973640080F2500406027

PLEASE DO NOT REPLY TO THIS EMAIL! This email has been automatically generated.

Billing Information

salman malallah
3601. lake mary
Flagstaff
AZ
US
86001
ssm264@nau.edu
4807998680

Order Items

128915 Cline Library 3D Pri...	x 1	\$38.98
--------------------------------	-----	---------

Payment Details

Visa
xxxxxxxxxxxx5369

Order Total

Total amount \$38.98

Please keep a copy of this email for your records.
PLEASE DO NOT REPLY TO THIS EMAIL! This email has been automatically generated.
If you have questions regarding this transaction, please contact the department that originated the transaction.



Receipt

Date: 04-19-2019
Order Number: 19040001973640080F2500405874

PLEASE DO NOT REPLY TO THIS EMAIL! This email has been automatically generated.

Billing Information

Saiman Malallah
3501 Lake Mary Rd.
Flagstaff
AZ
US
86001
sam264@nau.edu
4807998680

Order Items

128916 Cline Library 3D Pri... x 1 \$35.78

Payment

Details
Visa
xxxxxxxxxxxx5369

Order Total

Total amount: \$35.78

Please keep a copy of this email for your records.
PLEASE DO NOT REPLY TO THIS EMAIL! This email has been automatically generated.
If you have questions regarding this transaction, please contact the department that originated the transaction.

Team Member: Abdulwahab Zaidan

Action Item	Date Due	Date Completed	Result/Proof of Completion
Worked on the Final Presentation	04/18/2019	04/25/2019	N/A

<p>Made a meeting with Jenn in order to see the new supporting channel fits. (with Salman). The supporting channel fits just needs few editing</p>	<p>04/16/2019</p>	<p>04/16/2019</p>	
--	-------------------	-------------------	---

Team Member: Omar Alajmi

Action Item	Date Due	Date Completed	Result/Proof of Completion
<p>(with Salman) we worked on the Final draft of the poster based on the feedback we got</p>	<p>04/19/2019</p>	<p>04/19/2019</p>	<p>Done and have been submitted through BBlearn and sent by email.</p>

The following are the Action Items for next week:

Team Member	Action Items	Date Due
Ali Abdullah	1. Finalizing the work on the presentation	04/26/2019
Salman Malallah	1. Working on final Presentation - slides	04-26-2019
Abdulwahab Zaidan	1. Working on the final presentation	04/26/2019
Omar Alajmi	1. Work on the Final presentation.	04/26/2019